

# **BESSER**

## **VIBRAPAC**

**3 AT A TIME**

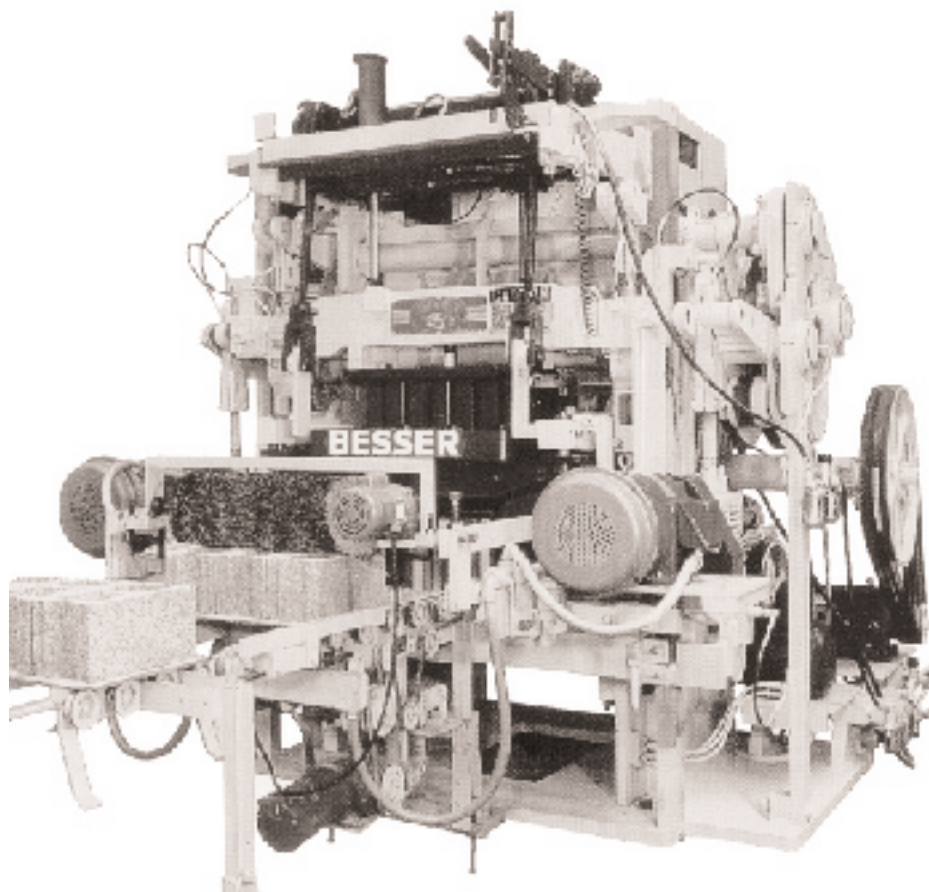

**INSTALLATION MANUAL**

**466365F9801US**

**OCTOBER 1999 • US\$250**

**BESSER** World Headquarters

801 Johnson St. • Alpena, Michigan, 49707 • U.S.A.  
Phone (517) 354-4111

# **BESSER**

COMPANY NAME: .....

SERIAL NUMBER: .....

ASSEMBLY NUMBER: .....

WIRING DIAGRAM NUMBER: .....

INSTALLATION DRAWING NUMBER: .....

# VIBRAPAC

## TABLE OF CONTENTS

LIST OF TABLES .....	ii
LIST OF ILLUSTRATIONS .....	ii
SAFETY BULLETIN .....	.iii
SAFETY SIGNS .....	.iv
SPECIFICATIONS .....	.viii
<b>PREPARATION</b>	
PREPARING THE LOCATION OF THE VIBRAPAC .....	1-1
<b>MACHINE HANDLING</b> .....	1-6
<b>INSTALLATION</b>	
TO INSTALL A VIBRAPAC .....	1-8

# VIBRAPAC

## LIST OF TABLES

### PREPARATION

1.1 I-beam Dimensions.....	1-2
----------------------------	-----

# VIBRAPAC

## LIST OF ILLUSTRATIONS

### PREPARATION

1.1 Side Elevation.....	1-1
1.2 Front Elevation.....	1-2
1.3 3-D View.....	1-3
1.4 Top View.....	1-4

### MACHINE HANDLING

1.5 Machine Handling.....	1-6
---------------------------	-----

### INSTALLATION

















1.6 Typical Vibrapac Installation.....	1-7
1.7 Right Side Elevation.....	1-8
1.8 Front Elevation.....	1-9
1.9 Pour Non-Shrink Grout Inside.....	1-10
1.10 Air Supply Connections.....	1-11

## SAFETY BULLETIN

This notice is issued to advise you that some previously accepted shop practices may not be keeping up with changing Federal and State Safety and Health Standards. Your current shop practices may not emphasize the need for proper precautions to insure safe operation and use of machines, tools, automatic loaders and allied equipment and/or warn against the use of certain solvents or other cleaning substances that are now considered unsafe or prohibited by law. Since many of your shop practices may not reflect current safety practices and procedures, particularly with regard to the safe operation of equipment, it is important that you review your practices to ensure compliance with Federal and State Safety and Health Standards.

### IMPORTANT

**The operation of any machine or power-operated device can be extremely hazardous unless proper safety precautions are strictly observed. Observe the following safety precautions:**

-  Always be sure proper guarding is in place for all pinch, catch, shear, crush and nip points.
-  Always make sure that all personnel are clear of the equipment before starting it.
-  Always be sure the equipment is properly grounded.
-  Always turn the main electrical panel off and lock it out in accordance with published lockout/tag-out procedures prior to making adjustments, repairs, and maintenance.
-  Always wear appropriate protective equipment like safety glasses, safety shoes, hearing protection and hard hats.
-  Always keep chemical and flammable material away from electrical or operating equipment.
-  Always maintain a safe work area that is free from slipping and tripping hazards.
-  Always be sure appropriate safety devices are used when providing maintenance and repairs to all equipment.
-  Never exceed the rated capacity of a machine or tool.
-  Never modify machinery in any way without prior written approval of the Besser Engineering Department.
-  Never operate equipment unless proper maintenance has been regularly performed.
-  Never operate any equipment if unusual or excessive noise or vibration occurs.
-  Never operate any equipment while any part of the body is in the proximity of potentially hazardous areas.
-  Never use any toxic flammable substance as a solvent cleaner.
-  Never allow the operation or repair of equipment by untrained personnel.
-  Never climb or stand on equipment when it is operational.

It is important that you review Federal and State Safety and Health Standards on a continual basis. All shop supervisors, maintenance personnel, machine operators, tool operators, and any other person involved in the setup, operation, maintenance, repair or adjustment of Besser-built equipment should read and understand this bulletin and Federal and State Safety and Health Standards on which this bulletin is based.

## SAFETY SIGNS

<b>Sign</b>	<b>Description</b>	<b>Required</b>
1	All Panels .....	1
2	Mixer .....	4
3	Concrete Products Machine.....	1
	Depalleter.....	2
4	Mixer .....	2
5	Skiploader .....	4
6	Skiploader/Mixer Platforms .....	8
7	Skiploader/Mixer Platforms .....	8
8	Vertical: Pallet Transport System .....	2
	Horizontal: LSC-40A/LSC-100 .....	6
	Pallet Transport System .....	4
9	Besser-Matic .....	4
10	Besser-Matic .....	4
11	Skiploader .....	4
12	All Panels .....	1
13	Overhead Block Transfer .....	4
14	Concrete Products Machine.....	1
15	Concrete Products Machine.....	2
16	Conveyors .....	12
17	Cuber .....	8
18	Cuber .....	3
	Block Turnovers.....	2
	Slat Conveyors.....	2

**To order safety decals, contact your local Besser representative  
or the Besser Central Order Department.  
Thank you!**



**1**

**Large 113236F0409**  
High Voltage  
Width 4 1/2 inch  
Height 9 5/8 inch  
**Small 113236F0204**  
High Voltage  
Width 2 inch  
Height 4 1/8 inch



**2**

**113237F0410**  
Mixer Blade Hazard  
Width 4 1/2 inch  
Height 1/4 inch



**3**

**113240F0307**  
Crush Hazard  
Width 3 1/2 inch  
Height 7 1/2 inch



**4**

**114692F1006**  
Nip Points  
Width 5 3/4 inch  
Height 9 1/2 inch



**5**

**114688F0906**  
Crush Hazard  
Width 6 1/4 inch  
Height 9 1/2 inch



**6**

**114689F0804**  
Fall Hazard  
Width 4 1/2 inch  
Height 7 3/4 inch



**7**

**114690F0805**  
Falling Objects  
Width 4 3/4 inch  
Height 8 inch



**8**

**Vertical: 113245F0704**  
**Horizontal: 113245F1005**  
Crush Hazard  
Vertical: Width 4 1/8 inch  
Vertical: Height 7 inch  
Horizontal: Width 10 inch  
Horizontal: Height 5 3/4 inch



**9**

**113242F0409**  
Crush Hazard  
Width 4 1/2 inch  
Height 9 5/8 inch



**10**

**113243F0410**  
Falling Objects  
Width 4 1/2 inch  
Height 10 inch



**11**

**114691F1006**  
Shear and Fall Hazards  
Width 5 3/4 inch  
Height 9 3/4 inch



**12**

**113249F0410**  
Safety instructions decal-  
Suggested Lock-out procedure  
Width 4 inch  
Height 10 inch



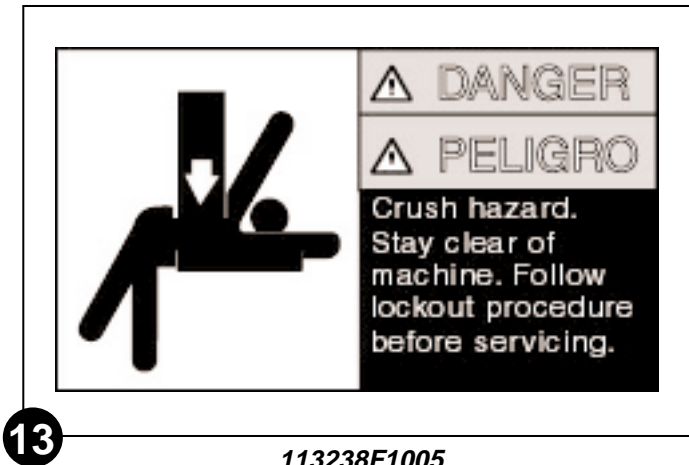

**13**

**113238F1005**  
Crush Hazard  
Width 10 inch  
Height 5 3/4 inch



**14**

**113239F0604**  
Crush Hazard  
Width 6 5/8 inch  
Height 4 inch

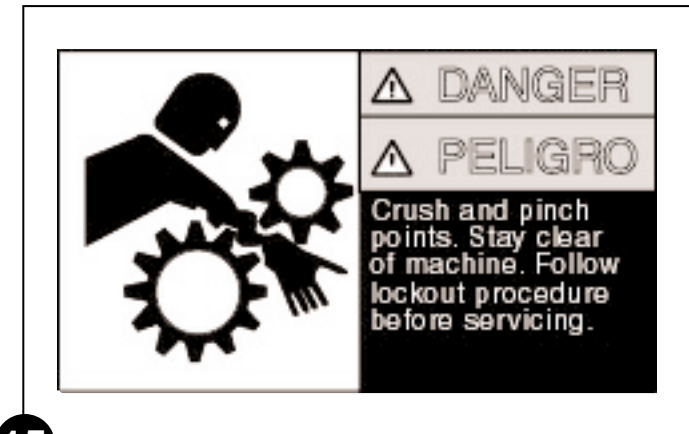

**15**

**113241F0605**  
Crush and Pinch Points  
Width 6 5/8 inch  
Height 4 inch

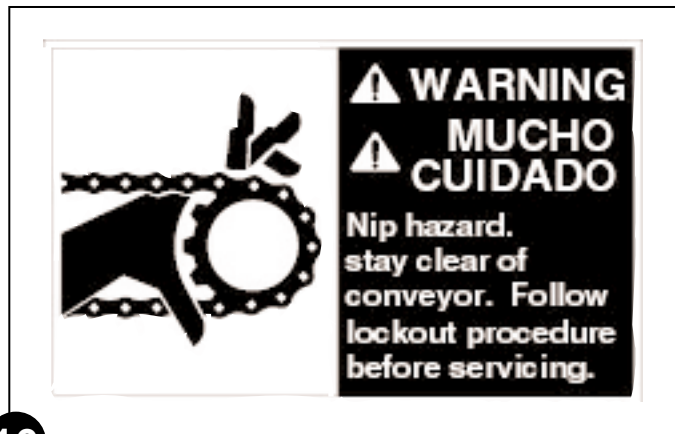

**16**

**113246F0704**  
Nip Hazard  
Width 7 inch  
Height 4 1/2 inch



**17**

**113247F1006**  
Crush Hazard  
Width 10 inch  
Height 6 inch



**18**

**113250F1006**  
Crush and Pinch Points Hazard  
Width 10 inch  
Height 6 inch

# VIBRAPAC SPECIFICATIONS

<b><u>TOTAL WEIGHT:</u></b>	36,000 Lbs [16,330 Kg]
<b><u>AIR LINE FITTING DIMENSIONS:</u></b>	1/2" [12mm]
<b><u>MINIMUM AIR PRESSURE:</u></b>	80 psi [5.5 bars]
<b><u>NOISE RATING:</u></b>	102 to 114 DBA
<b><u>MACHINE SPEED:</u></b>	up to 9 cycles / minute
<b><u>PRODUCTION CAPACITY:</u></b>	up to 1,620 blocks / hour
<b><u>MINIMUM PRODUCT SIZE REQUIREMENT:</u></b>	2 3/8" high [60mm]
<b><u>MAXIMUM PRODUCT SIZE REQUIREMENT:</u></b>	12" high [304.8mm]
<b><u>REVOLUTIONS PER MINUTE OF VIBRATOR MOTORS:</u></b>	1700 RPM
<b><u>REVOLUTIONS PER MINUTE OF MOLD SHAFTS:</u></b>	2800 RPM ( $\pm$ 20 RPM from left to right shaft)

**PALLET REQUIREMENTS:**

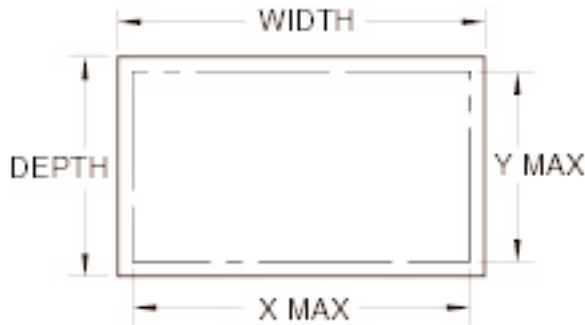

**WIDTH & DEPTH** = Actual size of steel pallet.  
**XMAX & YMAX** = Maximum production area of steel pallet.

WIDTH	DEPTH	THICK.*	X MAX	Y MAX	PALLET NO.
26.0" [660mm]	18.5" [470mm]	.313" [8mm]	25.0" [635mm]	17.625" [448mm]	470750F0001
26.0" [660mm]	20.5" [521mm]	.313" [8mm]	25.0" [635mm]	19.500" [495mm]	470750F002
26.0" [660mm]	26.0" [660mm]	.313" [8mm]	25.0" [635mm]	25.000" [635mm]	470750F0003
29.0" [737mm]	18.5" [470mm]	.313" [8mm]	26.5" [673mm]	17.625" [448mm]	470750F0004
29.0" [737mm]	20.5" [521mm]	.313" [8mm]	26.5" [673mm]	19.500" [495mm]	470750F0005
<b>THICKNESS TOLERANCE : -0.010" [0.25mm] / +0.030" [0.76mm]</b>					

\* Pallets should have same thickness for constant product.

Table A STEEL PALLET SPECIFICATIONS

## VIBRAPAC ELECTRICAL DATA

PLANT POWER SUPPLY (VOLTS)	TOTAL HORSEPOWER (HP)	TOTAL KILOWATTS (Kw)	CONTROL PANEL TRANSFORMER (VOLT-AMPS)	BRANCH CIRCUIT DISTRIBUTION SWITCH (AMPS)	BRANCH CIRCUIT FUSE FRS-R (AMPS)	BRANCH CIRCUIT FEEDER THHN	BRANCH CIRCUIT FEEDER CONDUIT	SHORT CIRCUIT INTERRUPTING CAPACITY (AIC)
220V-240V 50/60 Hz	38	28.4	1500	200	150	2 AWG 33.6MM <sup>2</sup>	1.0 IN. 25MM	200,000
380V 50 Hz	38	28.4	1500	100	100	4 AWG 21.6MM <sup>2</sup>	1.0 IN. 25MM	200,000
415V 50 Hz	38	28.4	1500	100	90	6 AWG 13.3MM <sup>2</sup>	0.75 IN. 20MM	200,000
440V-480V 50/60 Hz	38	28.4	1500	100	80	6 AWG 13.3MM <sup>2</sup>	0.75 IN. 20MM	200,000
575V 60 Hz	38	28.4	1500	100	70	8 AWG 8.4MM <sup>2</sup>	0.5 IN. 13MM	200,000

**Table B VIBRAPAC ELECTRICAL DATA**

Please consult the table above to find the appropriate electrical data for your VIBRAPAC. First, find your corresponding plant power supply in the first left column. You will then find the corresponding electrical data on the same row than your power plant supply.

**EX:** Your power plant supply is 460V at 60 Hz. According to the table, you will then get these values:

<b><u>PLANT POWER SUPPLY :</u></b>	460 Volts - 60 Hertz
<b><u>TOTAL HORSEPOWER :</u></b>	38
<b><u>TOTAL KILOWATTS :</u></b>	28.4
<b><u>CONTROL PANEL TRANSFORMER :</u></b>	1500 volt-amperes
<b><u>BRANCH CIRCUIT DISTRIBUTION SWITCH :</u></b>	100 amp
<b><u>BRANCH CIRCUIT FUSE RECOMMENDED (FRS-R) :</u></b>	80 amp
<b><u>BRANCH CIRCUIT FEEDER RECOMMENDED (THHN) :</u></b>	6 AWG (13.3mm <sup>2</sup> )
<b><u>BRANCH CIRCUIT FEEDER CONDUIT RECOMMENDED :</u></b>	0.75 in.(20mm)
<b><u>SHORT CIRCUIT INTERRUPTING CAPACITY :</u></b>	200,000 AIC

**VIBRAPAC ELECTRICAL COMPONENTS**

DEVICE	HORSEPOWER	KILOWATTS
MAIN DRIVE	15	11.2
VIBRATOR-RIGHT	10	7.5
VIBRATOR-LEFT	10	7.5
AGITATOR	2	1.5
AUTOFEED	1	0.7
<b>TOTAL :</b>	<b>38</b>	<b>28.4</b>

Table C VIBRAPAC ELECTRICAL COMPONENTS.

**SUMMARY OF ACOUSTICS**

Files #	+	MEM #	Frg.	Condition	Distance	Overall		< 550Hz		> 550Hz	
						C	A	C	A	C	A
1.	+	1/21	5 kHz	Start of cycle	0.5m	112	111	109	100	110	110
2.	+	2/22	5 kHz	End of cycle	0.5m	116	114	112	105	113	114
3.	+	3/23	5 kHz	Start of cycle	0.5m						
4.	+	4/24	1 kHz	End of cycle	0.5m						
5.	+	5/25	5 kHz	Start of cycle	1.0m	111	108	108	98	107	107
6.	+	6/26	5 kHz	End of cycle	1.0m	114	111	112	103	110	110
7.	+	7/27	1 kHz	Start of cycle	1.0m						
8.	+	8/28	1 kHz	End of cycle	1.0m						
9.	+	9/29	5 kHz	Start of cycle	2.0m	110	106	108	96	105	105
10.	+	10/30	5 kHz	End of cycle	2.0m	110	109	109	99	108	108
11.	+	11/31	1 kHz	Start of cycle	2.0m						
12.	+	12/32	1 kHz	End of cycle	2.0m						
13.	+	13/33	5 kHz	Start of cycle/ no pallet	0.5m	113	112	108	103	112	112
14.	+	14/34	5 kHz	End of cycle/ no pallet	0.5m	110	108	107	102	106	106
15.	+	15/35	1 kHz	Start of cycle/ no pallet	0.5m						
16.	+	16/36	1 kHz	End of cycle no pallet	0.5m						

Table D SUMMARY OF ACOUSTICS.

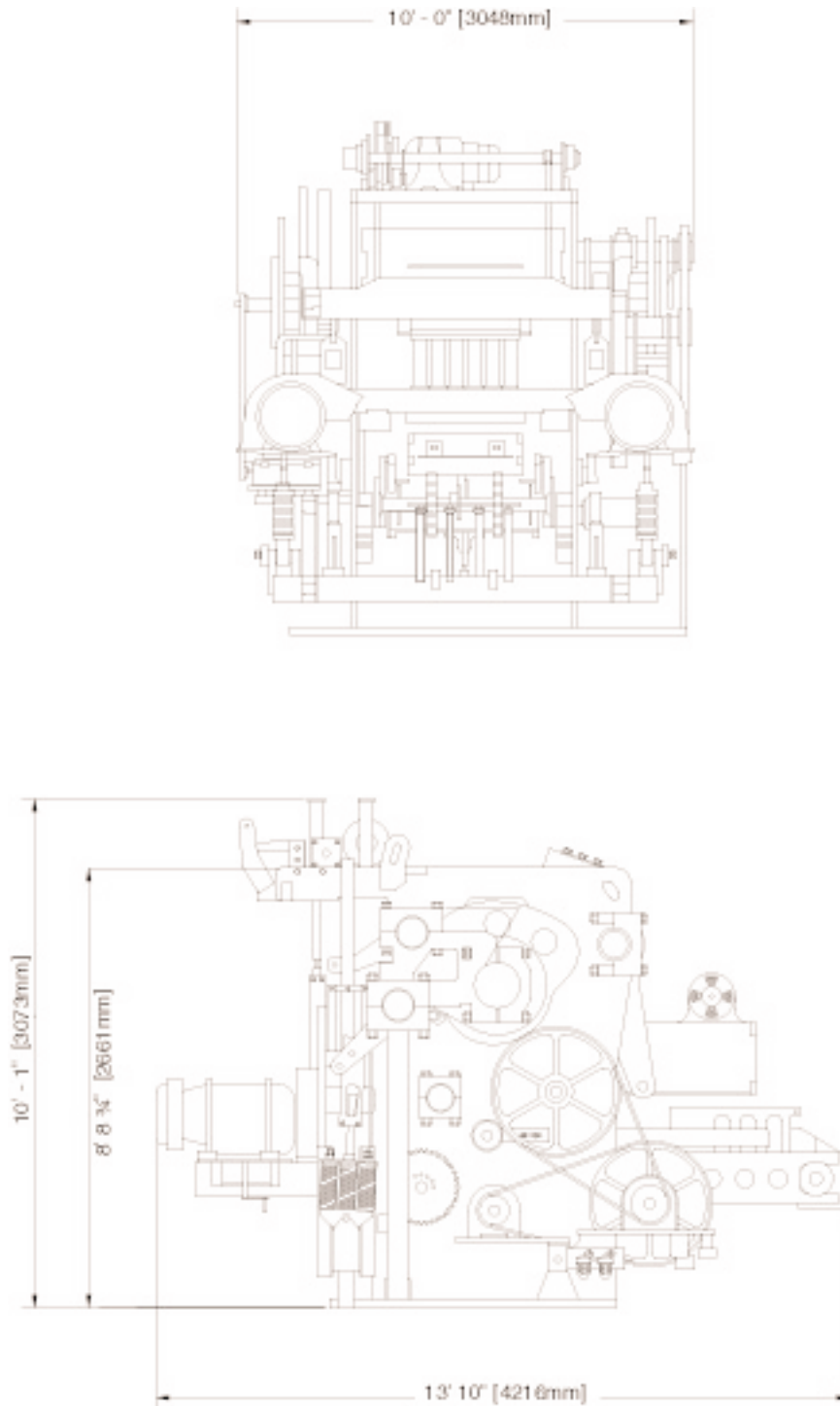
**OVERALL DIMENSIONS:**



# PREPARATION

The VIBRAPAC stands on a base plate that is fixed on beams. Those beams are fortified in a concrete slab and this independant platform must be placed in the floor. Use this section with the *Foundation drawing (# 466905)* and the *Installation drawing (# 466906)* to prepare the location and to install the VIBRAPAC. This section is not a replacement of the two drawings listed above; it is presented here for complementary information.

## PREPARING THE LOCATION OF THE VIBRAPAC

1. The framework should be prepared according to specifications presented in figure 1.1, 1.2 and 1.3.
2. The 10'6" x 9'0" [3200mm x 2743mm] framework must be surrounded by a 3/4" [19mm] thick strip of rigid type insulating board around VIBRAPAC concrete base to isolate vibration.

3. The length, width and thickness of the foundation specified in figures 1.1 and 1.2 represent minimum dimensions. The VIBRAPAC foundation can be increased in length, width or thickness to accommodate existing soil conditions.

**Note:** The concrete foundation dimensions should never be less than the dimensions specified. Make sure concrete foundation is at least 18 inches thick.

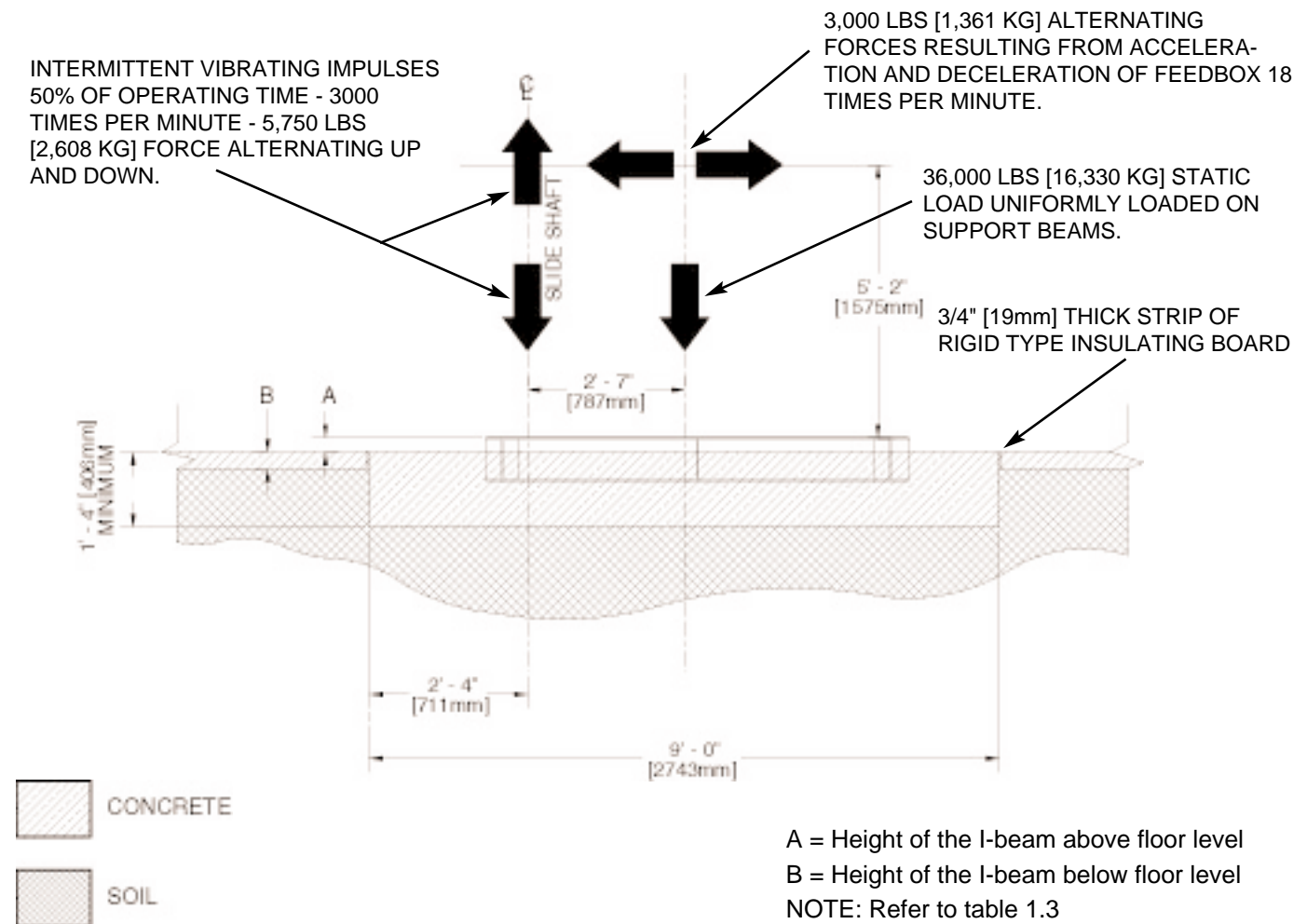

Figure 1.1 SIDE ELEVATION.

4. Cut the I-beams to proper length (see table 1.4).
5. Weld the I-beams together.

**Note:** 3/4" [19mm] reinforced steel bars should be welded to the I-beams going in various directions to give added support and anchorage to the machine. It should be sufficient to maintain beams in place while concrete is being poured.

6. Place the beams at the desired height. For recommended beam size relative to the desired distance between the base plate and the floor, consult table 1.4 below.

**IMPORTANT!** The centerline of the machine is not the same as the center of the concrete slab. The centerline of the block machine is offset to one side of the foundation (see figure 1.2).

7. Pour concrete to make base. We recommend a minimum 4000 psi (275 bar) concrete.

DISTANCE FROM FLOOR TO BOTTOM OF BASE PLATE DIMENSION (A) INCHES & [mm]	HEIGHT OF BEAM IN CONCRETE DIMENSION (B) INCHES & [mm]	WIDTH OF BEAM DIMENSION (C) INCHES & [mm]	SIZE AND WEIGHT OF BEAM RECOMMENDED INCHES & LBS/FT	SIZE AND WEIGHT OF BEAM IN CONCRETE mm & Kg/m
1 [25]	5 [127]	6 [152]	W6 @ 25 #/FT	W152 @ 37.2 Kg/m
2 [51]	4 [102]	6 [152]	W6 @ 25 #/FT	W152 @ 37.2 Kg/m
3 [76]	9 [229]	5 [127]	S12 @ 31.8 #/FT	S305 @ 47.3 Kg/m
4 [102]	8 [203]	5 [127]	S12 @ 31.8 #/FT	S305 @ 47.3 Kg/m
5 [127]	7 [178]	5 [127]	S12 @ 31.8 #/FT	S305 @ 47.3 Kg/m
6 [152]	6 [152]	5 [127]	S12 @ 31.8 #/FT	S305 @ 47.3 Kg/m
7 [178]	5 [127]	5 [127]	S12 @ 31.8 #/FT	S305 @ 47.3 Kg/m
8 [203]	7 [178]	5.5 [140]	S15 @ 42.9 #/FT	S381 @ 63.8 Kg/m
9 [229]	6 [152]	5.5 [140]	S15 @ 42.9 #/FT	S381 @ 63.8 Kg/m
9.625 [244]	5.375 [137]	5.5 [140]	S15 @ 42.9 #/FT	S381 @ 63.8 Kg/m
10.25 [260]	4.75 [121]	5.5 [140]	S15 @ 42.9 #/FT	S381 @ 63.8 Kg/m

Table 1.4

Note: Dimension "A"=1" [25mm] for use with standard Bessermatic equipment. Any installation different from 1" [25mm] is special.

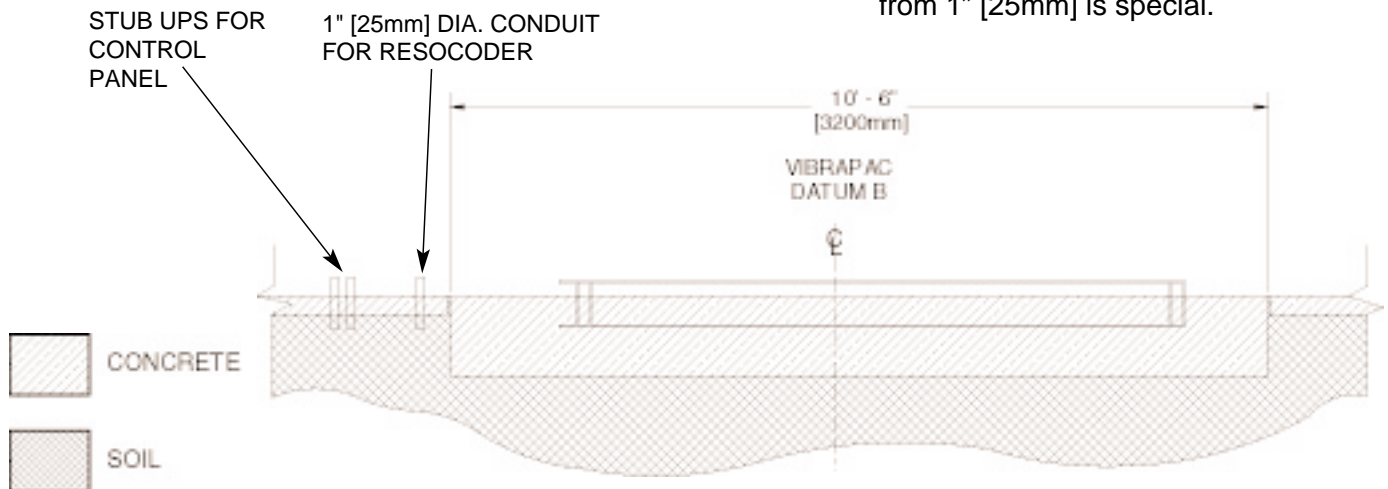

Figure 1.2 FRONT ELEVATION.



- The electrical panel can be installed on any side of the machine but is usually installed on the opposite side of unloader (see figure 1.4). It can also be installed in any location to accommodate specific plant layout. In a hot and/or humid weather area, all controls should be placed in a closed and air conditioned room

**Note:** To comply with articles 110-9 and 110-10 of the national electrical code, American customers shall supply a branch circuit protective device to feed this control. The protective device shall have a short circuit interrupting rating of no less than the available short circuit current. Failure to do so could result in a rupture of the protective device while attempting to clear a fault. Besser Company recommends the use of protective devices with interrupting ratings of no less than 200,000 AMPS RMS symmetrical. See the electrical data chart on drawing #466905 for recommended protection. [As for customers outside the US, please check with your country's electrical codes and make sure

you comply with all laws concerning electrical devices.]

- A conduit for electrical panel can be installed as shown on figure 1.4.
- A conduit for the resocoder must also be installed as shown on figure 1.4.
- The Graphic Control Station has to be connected to the electrical panel. Run two 3/4 inches conduits from electrical panel to display control station (one for communication cable, one for power). The conduit wire length can not be greater than 45 linear feet [13.7 meters]. The location is shown on the plant layout drawing.

**Note:** Do not run any conduits through or under machine foundation. Moreover, all conduits to be below concrete and stub-ups are to extend 3 inches [76 mm] above floor.

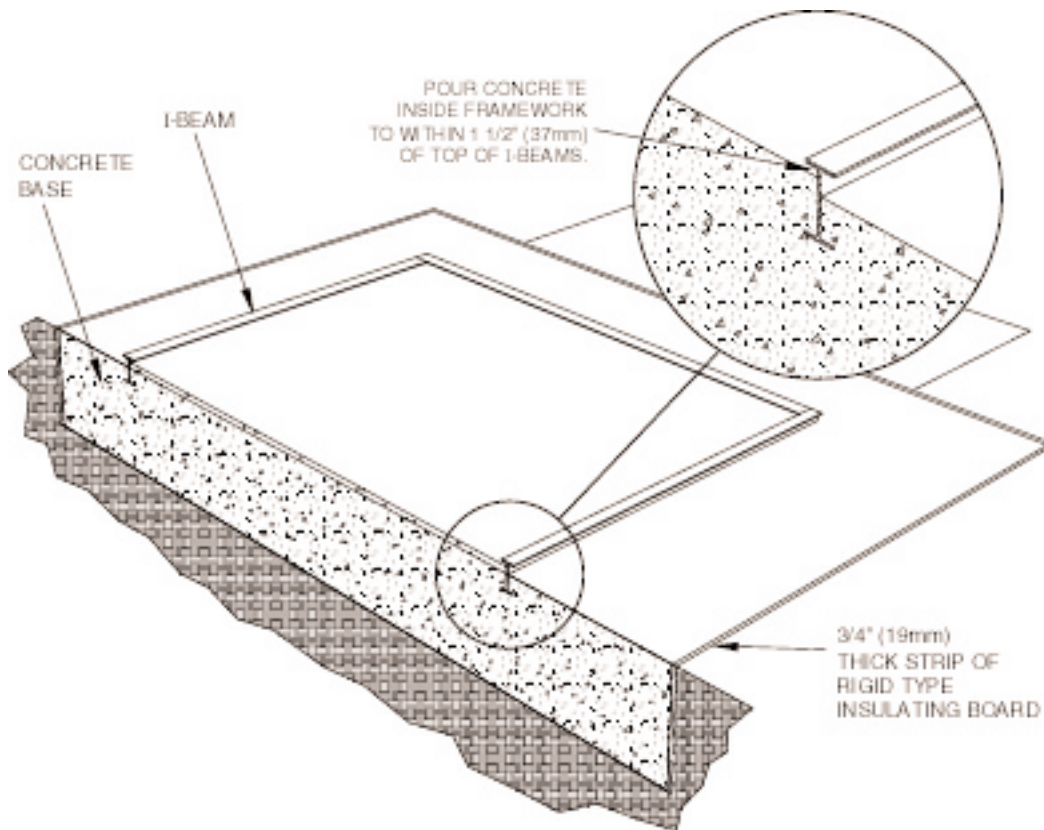

Figure 1.3 3-D VIEW.

**Note:** Refer to table 1.4 for "C" value.

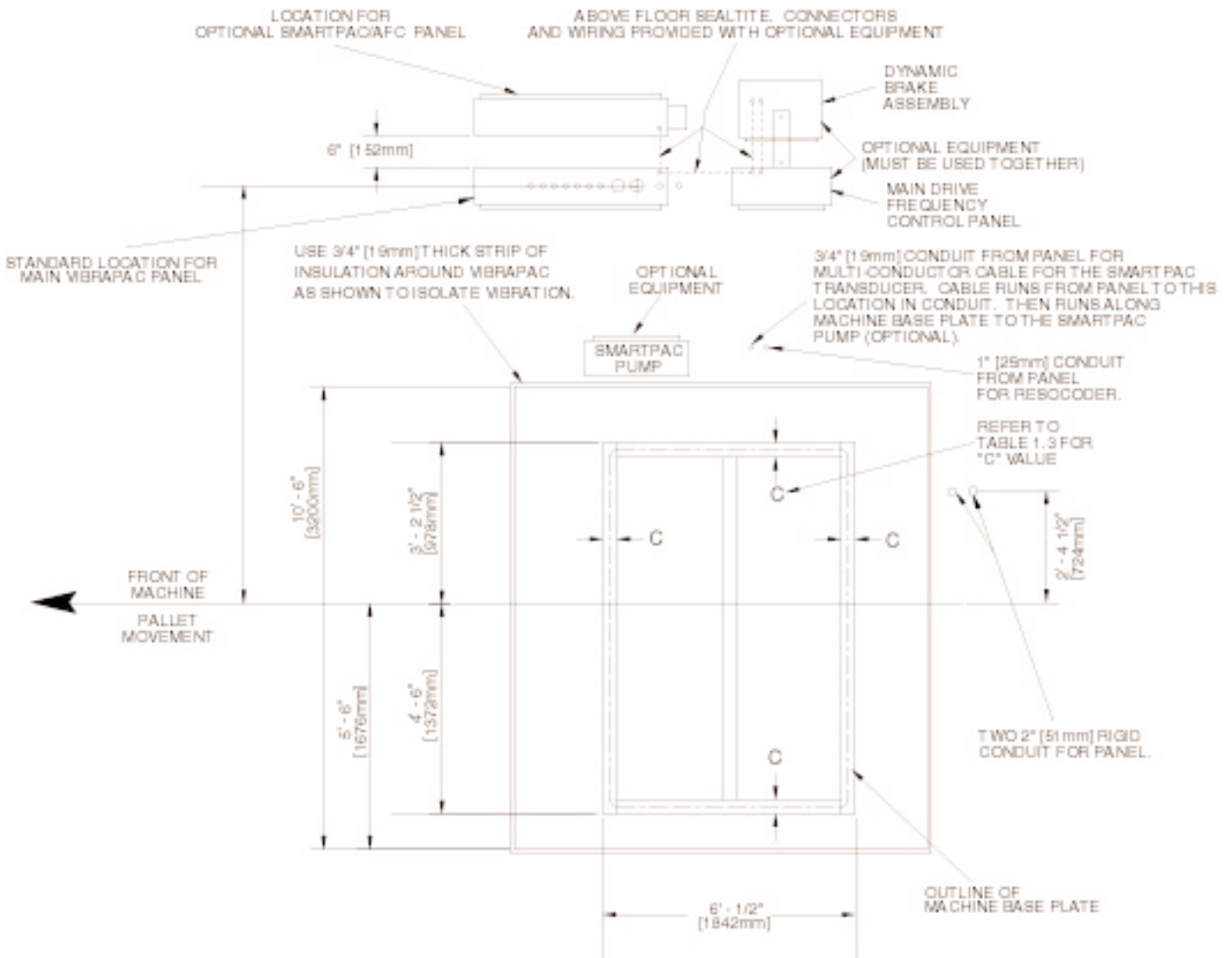

Figure 1.4 TOP VIEW (PALLET ENTRANCE ON RIGHT HAND SIDE OF MACHINE).

12. Once the frame is properly located and leveled, pour concrete inside within 1-1/2" [38mm] of top of I-beam to allow for machine grouting. Do not pour the concrete up to the top of the beams. This also includes the area of concrete between the I-beams. Refer to figure 1.3.

**Note:** The top of the I-beams needs to be level (within 1/64" [0.4mm]) around the elevation given on the installation prints. For optimum equipment performance, these steel frames need to be level and at the proper elevation.

## MACHINE HANDLING

---

The figure below shows where the machine should be hooked for handling.

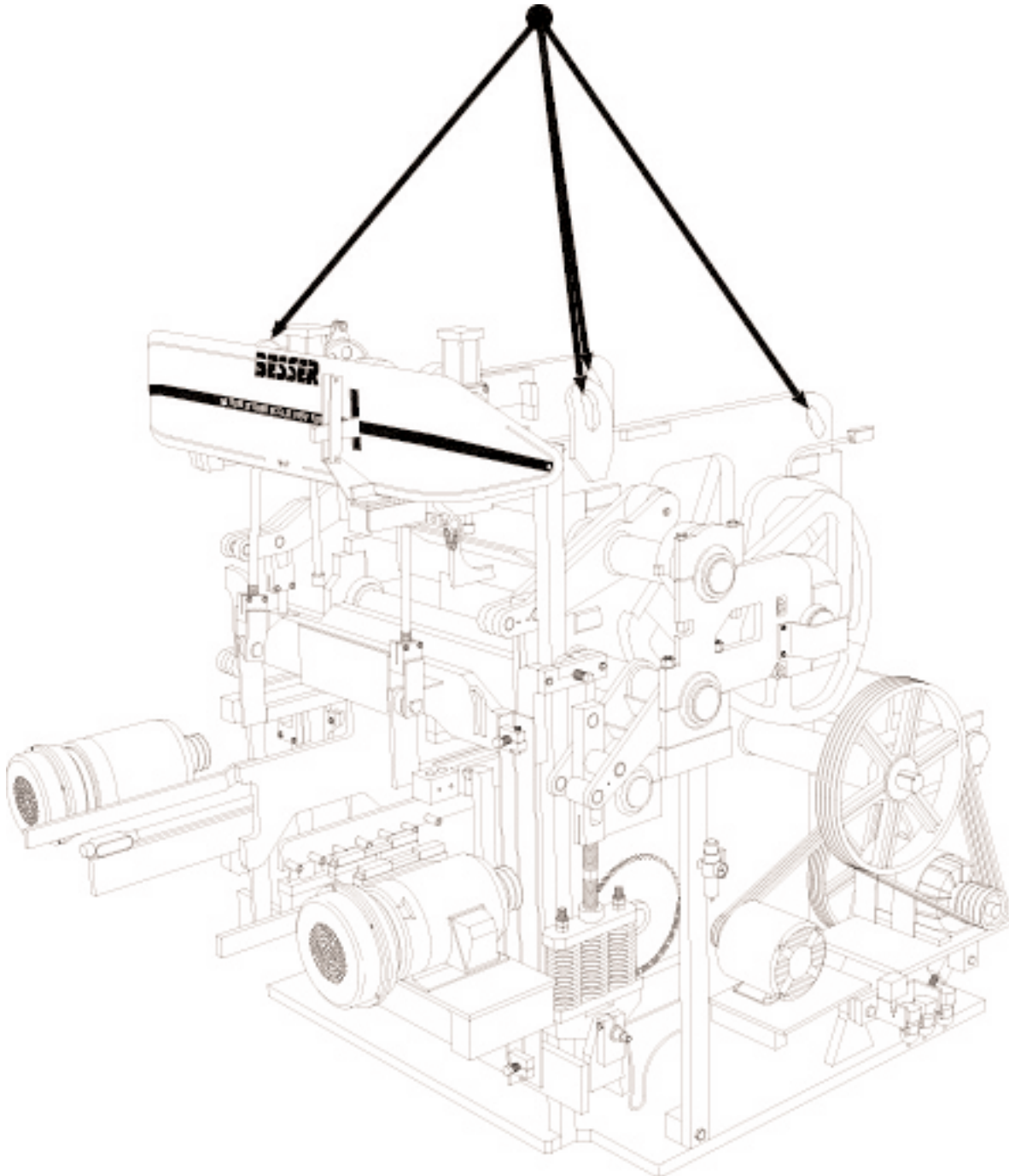

---

Figure 1.5 MACHINE HANDLING.

# INSTALLATION

---

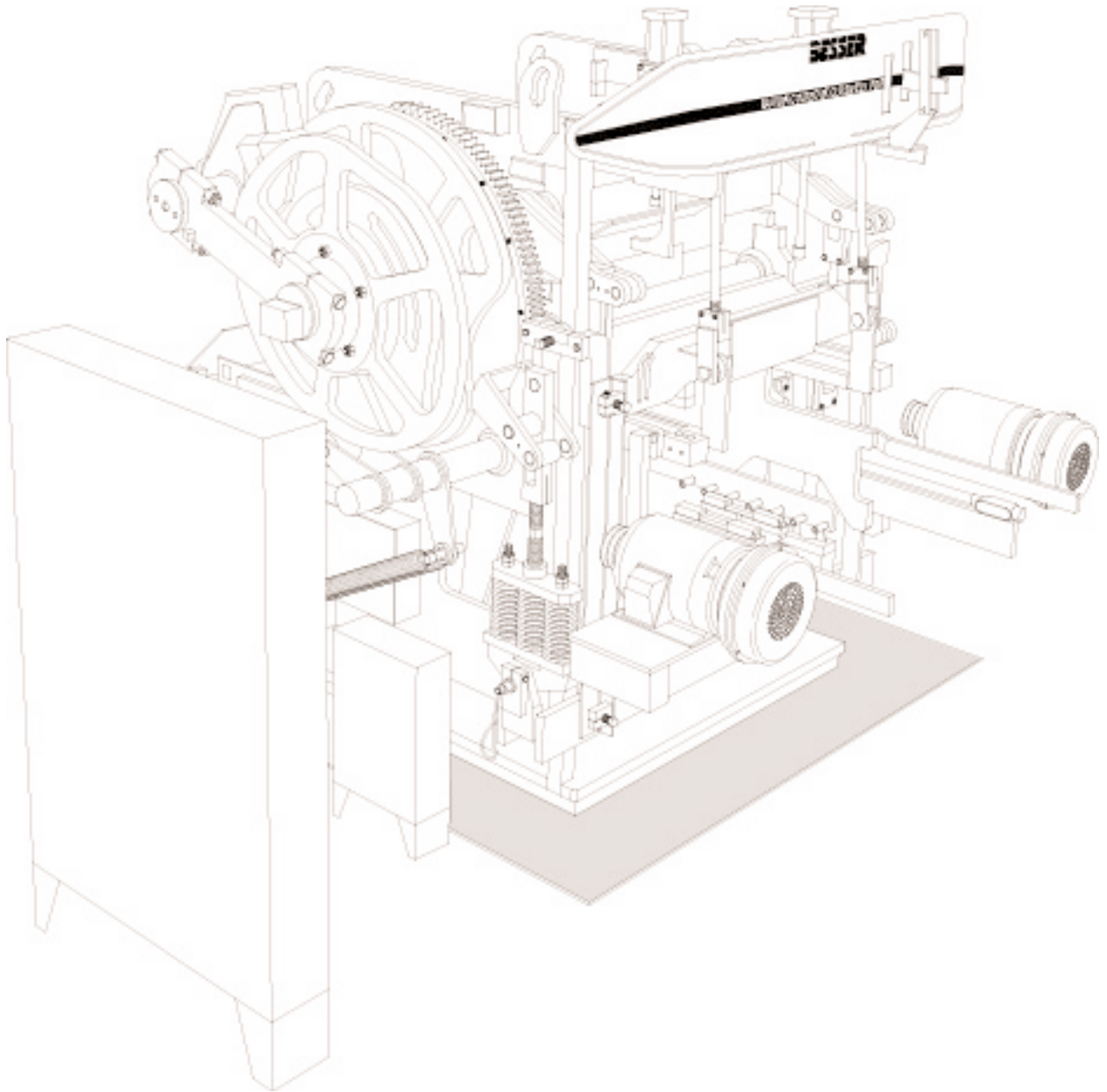

Figure 1.6 TYPICAL VIBRAPAC INSTALLATION.

**TO INSTALL A VIBRAPAC:**

1. Establish center lines for machine.

**Note:** The centerline of the machine is **not** the same as the center of the concrete slab. The centerline of the block machine is offset to one side of the foundation as shown in figure 1.2.

2. Clean area inside support steel and top of steel.
3. Make sure a 3/4" [19mm] strip of insulation has been placed between the machine foundation and the plant floor to isolate the vibration to the machine foundation (figure 1.3).
4. Place machine on support steel and align with center lines.
5. Level machine using machined area next to side-frames to within 1/32" [0.8mm]. If required, use 6" [152mm] long shim every foot [305mm]. Check machine vertical level on both slide shafts (must be plumb both ways). Machine should be levelled front to back, and side to side, to prevent wear and

misalignment. Refer to figures 1.7 and 1.8.

6. Weld machine to steel with 5/8" [16mm] skip weld. Make sure machine stays aligned with center line during welding. Weld over the shims. Refer to figures 1.7 and 1.8.
7. Non-shrink grout should be placed inside the I-beams through the center hole once the block machine has been placed and test run (figure 1.9). This will prevent eventual weld fatigue or base plate flex. 3 3/4 cu.ft. (1.14 m<sup>3</sup>) of grout is necessary for every inch below the base.
8. Make air connections. (Refer to figure 1.10 on page 18)
  - a. 28 SCFM at 80 psi [5.5 bars] on right side of machine for air compaction (optional).
  - b. 1 SCFM at 80 psi [5.5 bars] on right side of machine for other machine components.
  - c. 9 SCFM at 80 psi [5.5 bars] for Smartpac option (remote location).

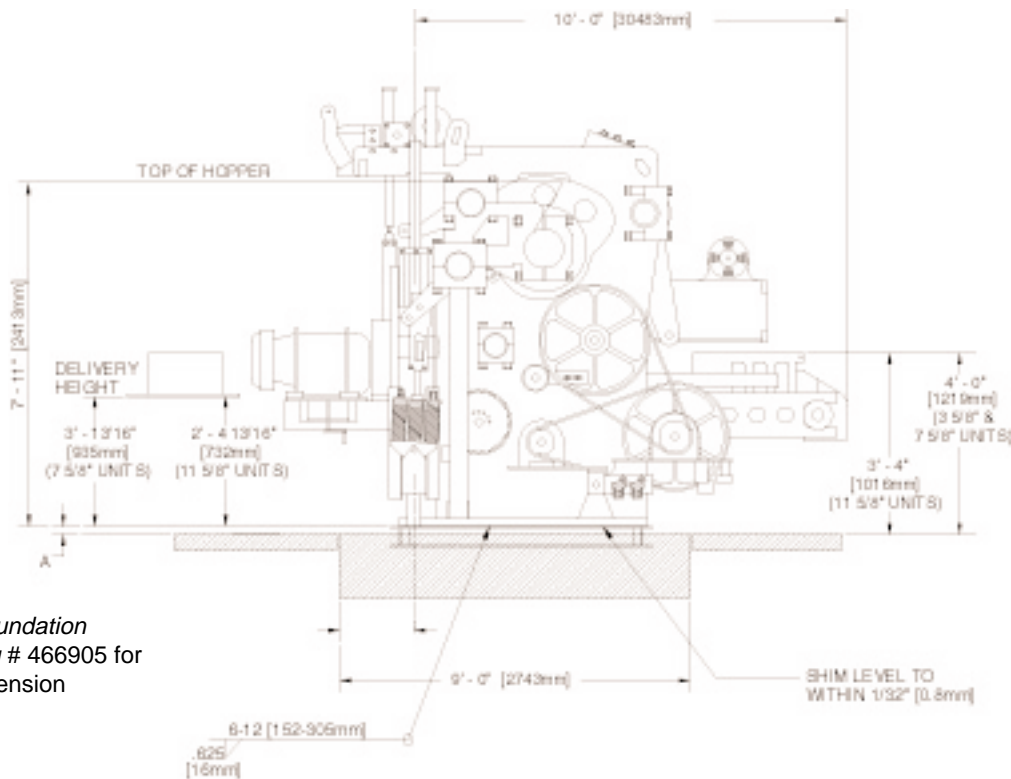

Figure 1.7 RIGHT SIDE ELEVATION.

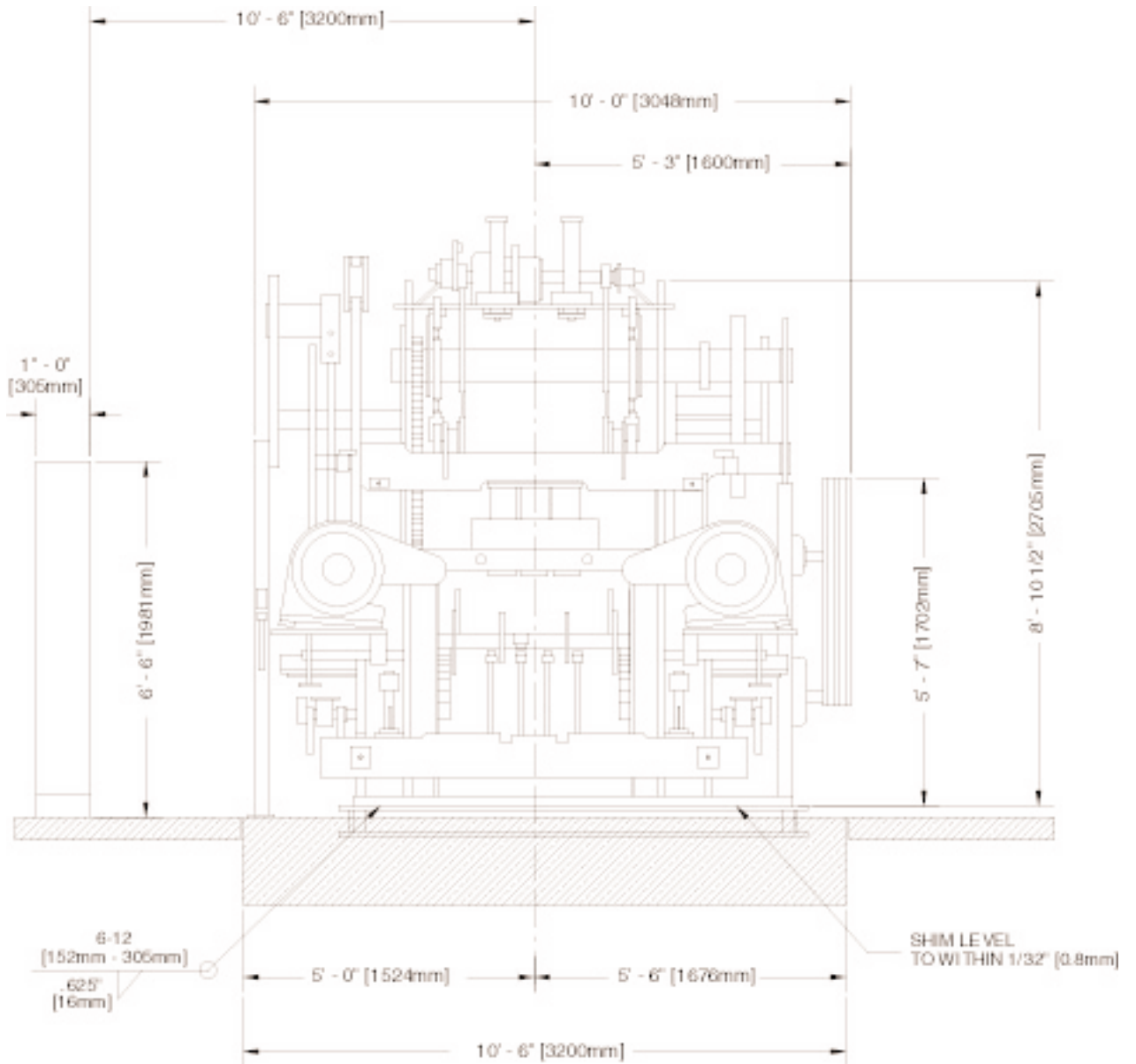

Figure 1.8 FRONT ELEVATION.



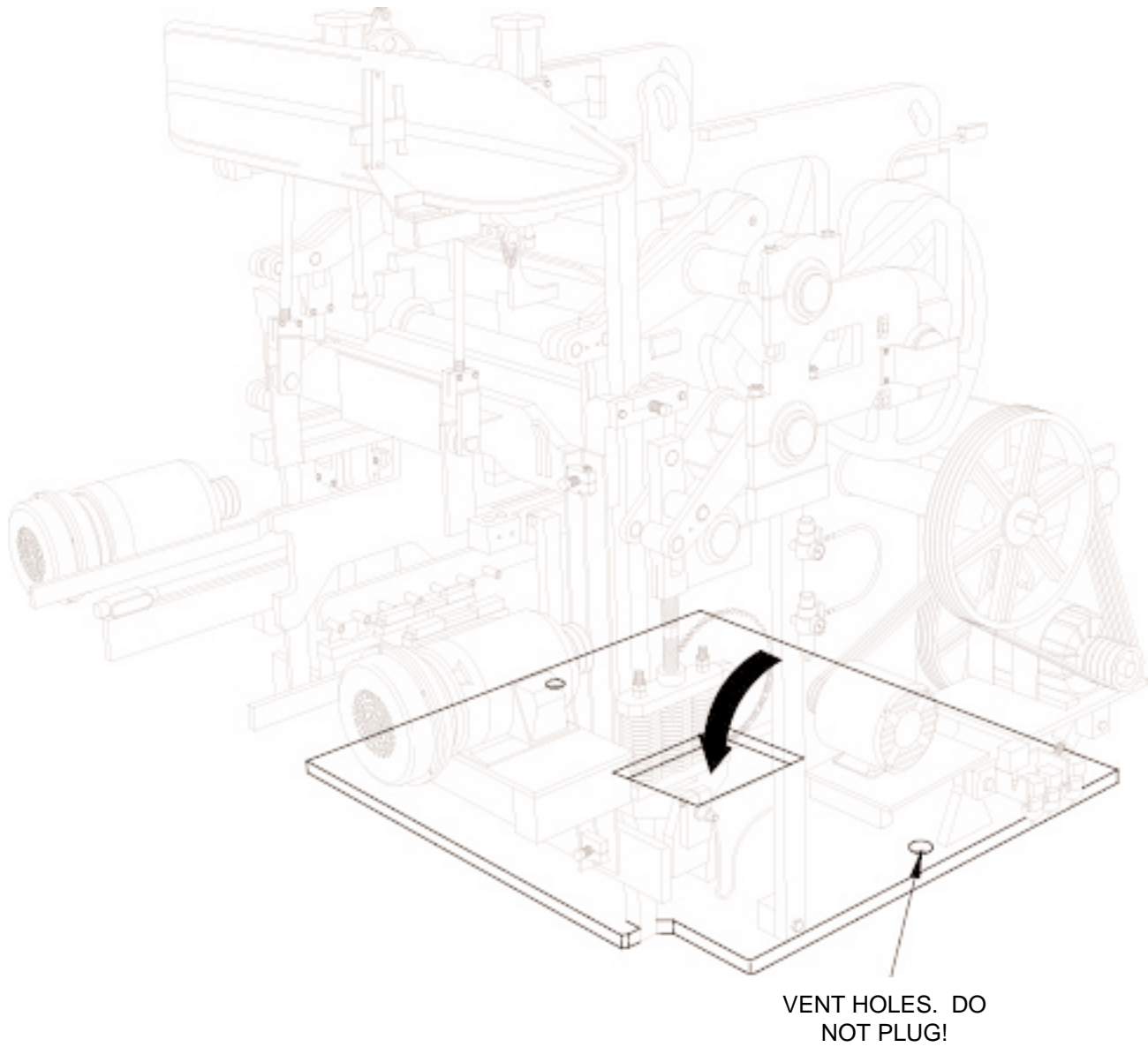

Figure 1.9 POUR NON-SHRINK GROUT INSIDE. FILL-UP TO TOP OF MACHINE BASE PLATE



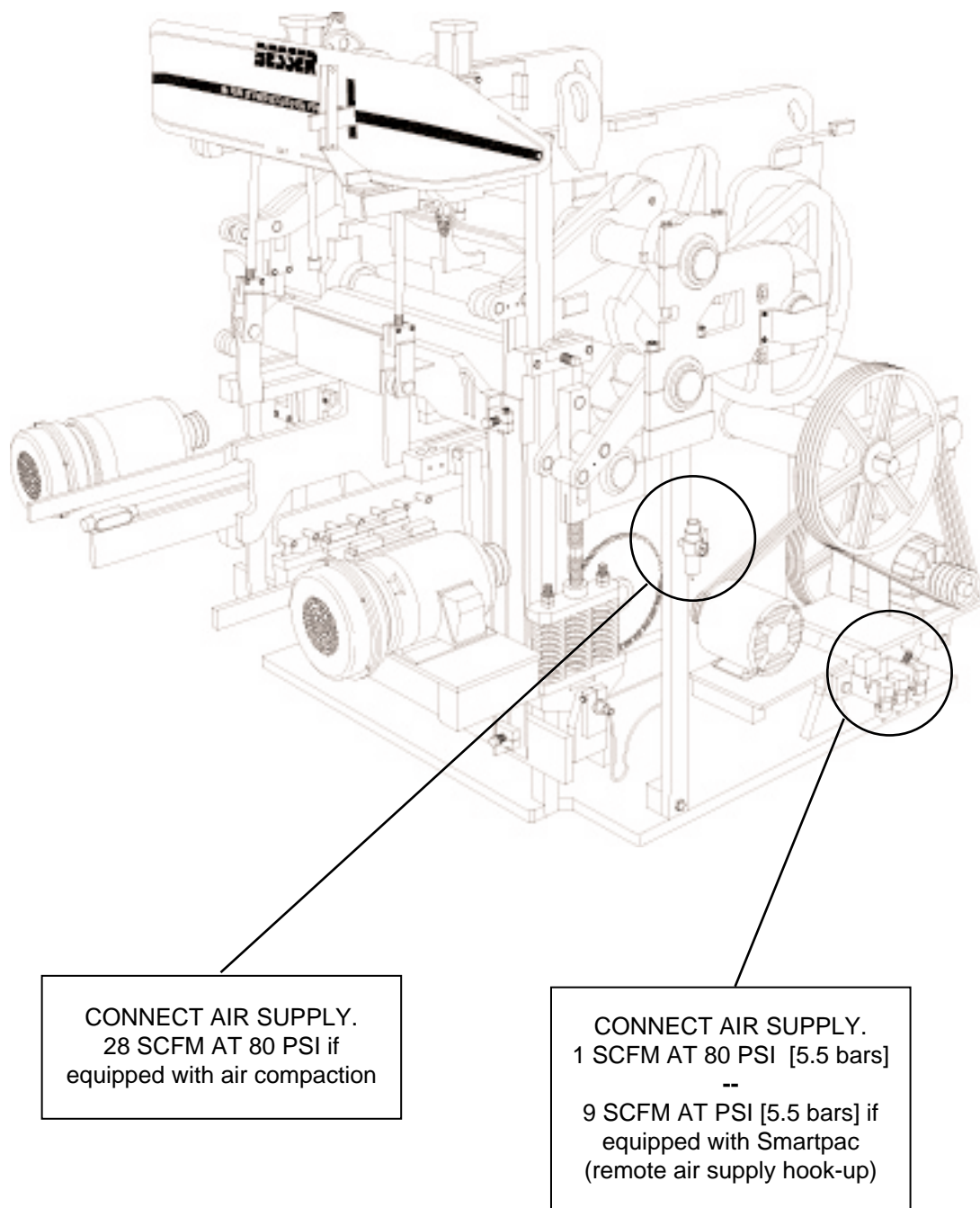

Figure 1.10 AIR SUPPLY CONNECTIONS.

9. Hopper **MUST NOT** be welded or bolted to machine. It has to be supported independantly from machine.
10. Check direction of rotation of vibrating shafts.  
The left side motor should be wired so it turns

clockwise and the right side motor turns counter-clockwise when viewed from front of machine (see figure 1.11).

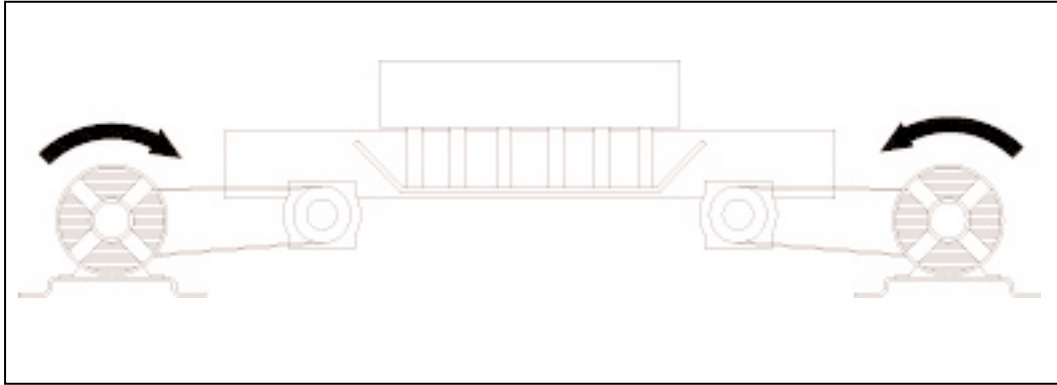

Figure 1.11 VIBRATING SHAFT ROTATION.