

Using the Encoder for Allen Bradley SLC-500 Programmable Logic Controllers

The Encoder is a Rotary Sensor which provides the Programmable Logic Controller (PLC) with a "0" to "359" degree value. The unit operates on 24 VDC plus or minus 1.0 VDC and is connected with a 50 foot cable between the Encoder and input module 1:3. The word value may be monitored by using the ROTARY SENSOR screen.

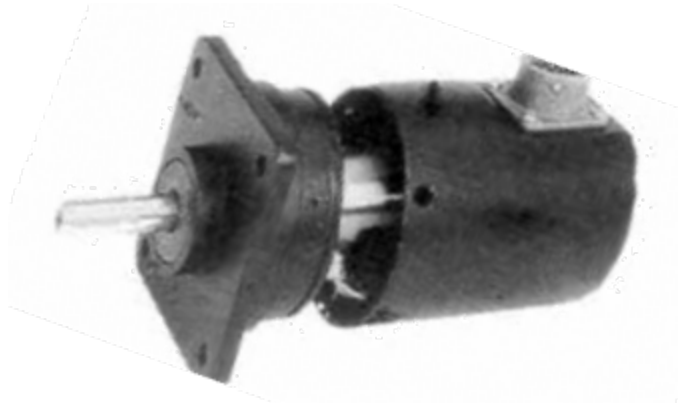

1. Make sure the coupler connecting the Rotary Sensor shaft to your machine is making proper connection to the prospective shaft.
1. Make sure that the "ms" connector on the cable is screwed all the way into the mating "ms" connector on the Rotary Sensor.
2. Check continuity on the Rotary Sensor cable to verify that Pin "A" on the connector is making continuity to the black wire at the other end of the cable. Next check Pin "B" to white, "C" to grey, etc. until complete. If the wire does not check out properly, repair or replace cable.
3. Check to make sure that the shield on the cable is tied to earth ground and that one of the screws on the mating "ms" connector on the Rotary Sensor is tied to the same earth ground.
4. Check the resistance from the Black/12 Gauge wire to earth ground. You must be reading at least 100K Ohms or you will get an erratic reading from the Rotary Sensor. If you are not getting this reading, make sure that Black/12 Gauge wire is not tied to earth ground. This wire should be connected to the common for the power supply and the signal common.
5. Check the voltage from the White/12 Gauge wire to the Black/12 Gauge wire. You should be reading +24, plus or minus 1.0 VDC for P/N E9N-B0360-BPCFS or E7B-B0360-8P0FS (Besser Part Number 454125). If not, check the power supply.
6. Check the voltage from the White/Green wire to the Black/12 Gauge wire. You must be reading the supply VCC voltage level. If not, check out the supply power source that is powering the outputs.

Using the Encoder for Allen Bradley SLC-500 Programmable Logic Controllers

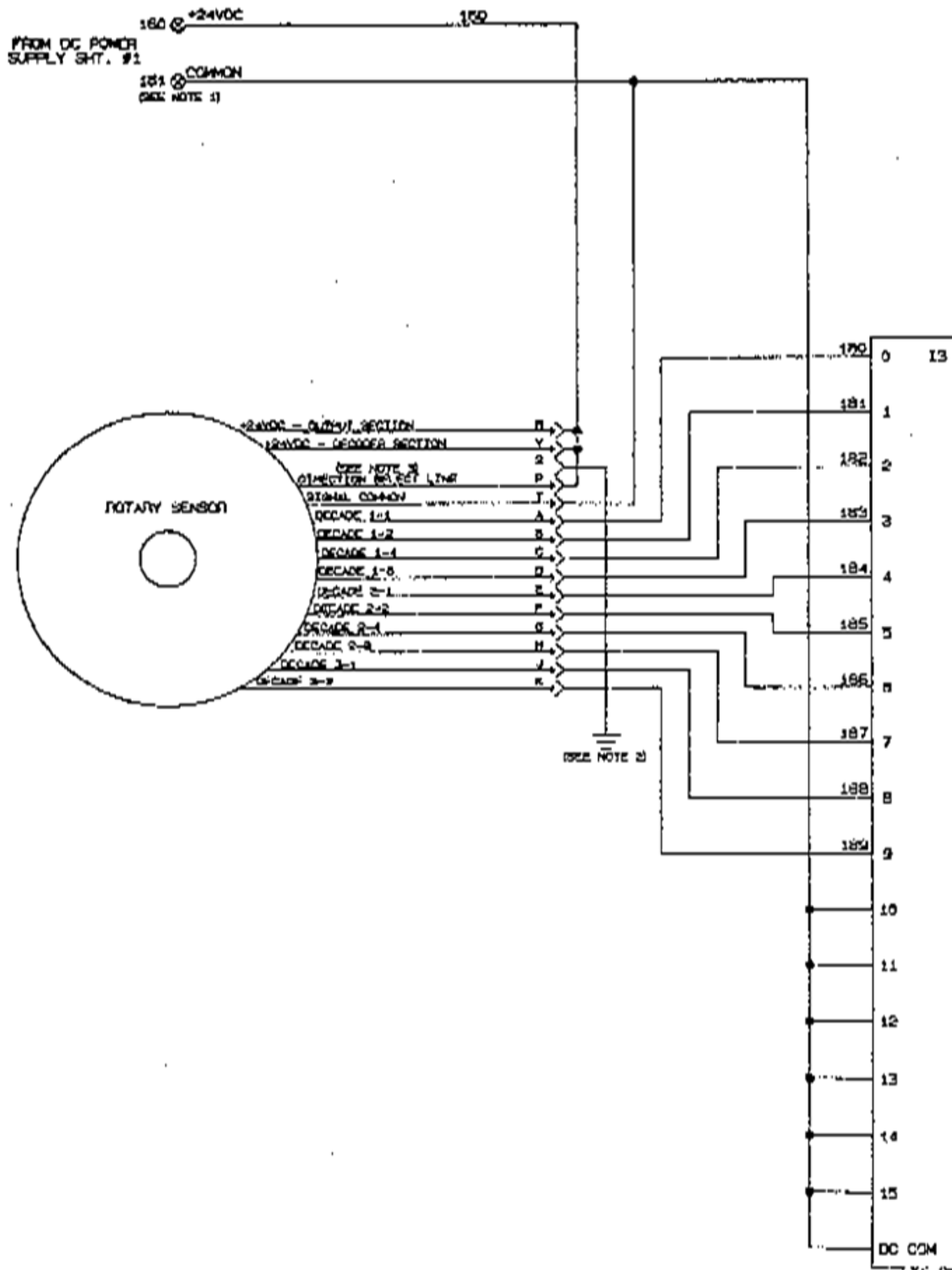

Using the Encoder for Allen Bradley SLC-500 Programmable Logic Controllers

ROTARY SENSOR WIRE COLOR CODE		
WIRE COLOR	WIRE NO.	PIN LETTER
WHITE/GREEN	160	R
WHT/12 GAUGE	160	V
SHIELD	GND	S
WHITE/RED	160	P
BLK/12 GAUGE	161	T
BLACK	180	A
WHITE	181	B
GREY	182	C
VIOLET	183	D
BLUE	184	E
GREEN	185	F
YELLOW	186	G
ORANGE	187	H
RED	186	J
BROWN	189	K

NOTE: 1

This equipment uses isolated signal common. Failure to assure at least 100K Ohms resistance between signal, common, and earth ground may cause erratic output data.

NOTE: 2

The shield drain wire should be connected to earth ground at one end of the cable. Make this connection at the panel side of the cable.

NOTE: 3

DO NOT connect Pin-P (White/Red) if P/N E7B-B0360-8P90FS is used. This unit has a switch on the back for direction selection. Otherwise follow the instructions below.

DIRECTION SELECT LINE

LOGIC 1 - Increase count in CCW (Counter clock-wise) direction if rotary sensor is mounted on left side of machine. Connect pin "P" to wire #160 as shown.

LOGIC 2 - Increase count in CW (Clock-wise) direction if encoder is mounted on right side of machine. Connect pin "P" to wire 161.

Using the Encoder for Allen Bradley SLC-500 Programmable Logic Controllers

SAFETY BULLETIN

This notice is issued to advise you that some previously accepted shop practices may not be keeping up with changing Federal and State Safety and Health Standards. Your current shop practices may not emphasize the need for proper precautions to insure safe operation and use of machines, tools, automatic loaders and allied equipment and/or warn against the use of certain solvents or other cleaning substances that are now considered unsafe or prohibited by law. Since many shop practices may not reflect current safety practice and procedures, particularly with regard to the safe operation of equipment, it is important that you review your practices to ensure compliance with Federal and State Safety and Health Standards.

IMPORTANT

The operation of any machine or power-operated device can be extremely hazardous unless proper safety precautions are strictly observed. Observe the following safety precautions:

ALWAYS:

- ✓ Be sure proper guarding is in place for all pinch, catch, shear, crush, and nip points.
- ✓ Be sure that all personnel are clear of the equipment before starting it.
- ✓ Be sure the equipment is properly grounded.
- ✓ Turn the main electrical panel off and lock it out in accordance with published lockout/tagout procedures prior to making adjustments, repairs, and maintenance.
- ✓ Wear appropriate protective equipment such as safety glasses, safety shoes, hearing protection, and hard hats.
- ✓ Keep chemical and flammable material away from electrical or operating equipment.
- ✓ Maintain a safe work area that is free from slipping and tripping hazards.
- ✓ Be sure appropriate safety devices are used when providing maintenance and repairs to all equipment.

Using the Encoder for Allen Bradley SLC-500 Programmable Logic Controllers

NEVER:

- ✓ Exceed the rated capacity of a machine or tool.
- ✓ Modify machinery in any way without prior written approval of the Besser Engineering Department.
- ✓ Operate equipment unless proper maintenance has been regularly performed.
- ✓ Operate any equipment if unusual or excessive noise or vibration occurs.
- ✓ Operate any equipment while any part of the body is in the proximity of potentially hazardous areas.
- ✓ Use any toxic flammable substance as a solvent cleaner.
- ✓ Allow the operation or repair of equipment by untrained personnel.
- ✓ Climb or stand on equipment when it is in operation.

It is important that you review Federal and State Safety and Health Standards on a continual basis. All shop supervisors, maintenance personnel, machine operators, tool operators, and any other person involved in the setup, operation, maintenance, repair or adjustment of Besser-built equipment should read and understand this bulletin and Federal and State Safety and Health Standards on which this bulletin is based.